

CH7525 4 Lane DisplayPort to HDMI Converter

FEATURES

- Compliant with DisplayPort Specification version 1.2a and Embedded DisplayPort (eDP) Specification version 1.3
- Up to 4 Main Link Lanes at either 1.62Gb/s or 2.7Gb/s (HBR) link rate supported
- Support color depth 6/8/10/12bits
- HDMI transmitter compliant with HDMI specification version 1.4b and DVI specification version 1.0
- HDMI transmitter supports up to 300 MHz TMDS clock, and supports up to 3.0Gbps data rate for video timing of 1920x1080@120Hz or 4Kx2K@30Hz
- Supports Enhanced Framing Mode
- Fast and full Link Training for embedded DisplayPort system
- Support eDP Authentication: Alternative Scramble Seed Reset and Alternative Framing
- DisplayPort receiver auto equalization supported for the compensation of input signal attenuation
- Support Spread Spectrum Clocking (de-spreading) for EMI reduction
- HDCP engine compliant with HDCP 1.4 specification with internal HDCP Keys
- On-chip Audio Decoder which support 8 channel Audio input from DP Rx and output from HDMI Tx with sample rate up to 192KHz
- Embedded MCU to handle the control logic
- Support device boot up by loading firmware from On Chip Flash automatically
- Integrated EDID Buffer
- 2 work modes: connect 27MHz crystal, inject 27MHz clock
- DP input detection supported
- Support Auto Power Saving mode and low stand-by current
- DP AUX channel and IIC slave interface are available for firmware update and debug
- Low power architecture
- RoHS compliant and Halogen free package
- HBM 4KV ESD Performance
- Offered in 48-Pin QFN package (6 x 6 mm)

APPLICATION

- Notebook/Ultrabook
- Tablet Device
- Handheld/Portable Device
- DP to HDMI cable
- DP to HDMI Adapter/Docking Station

GENERAL DESCRIPTION

Chrontel's CH7525 is a low-cost, low-power semiconductor device that translates the DisplayPort signal to HDMI/DVI. This innovative DisplayPort receiver with an integrated HDMI Transmitter is specially designed to target the notebook/ultrabook, tablet device and PC market segments. Through the CH7525's advanced decoding/encoding algorithm, the input DisplayPort high-speed serialized multimedia data can be seamlessly converted to HDMI/DVI output.

The CH7525's DP/eDP receiver is compliant with the DisplayPort Specification 1.2a and the Embedded DisplayPort Specification version 1.3. With internal HDCP key Integrated, the device support HDCP 1.4 specifications. In the device's receiver block, which supports four DisplayPort Main Link Lanes input with data rate running at either 1.62Gb/s or 2.7Gb/s, can accept RGB digital formats in either 18 bit or 24-bit, and converted the input signal to HDMI output up to 1920x1080@120Hz or 3840x2160@30Hz. Leveraging the DisplayPort's unique source/sink "Link Training" routine, the CH7525 is capable of instantly bring up the video display to the HDMI/DVI TV/Monitor when the initialization process is completed.

The CH7525 also supports up to 8-channel audio input from DP Rx and output from HDMI Tx with sample rate up to 192 KHz. Available audio bandwidth depends on the pixel clock frequency, the video format timing, and whether or not content protection re-synchronization is needed.

With sophisticated MCU and the On Chip Flash, CH7525 support auto-boot and EDID buffer. Leveraging the firmware auto-loaded from Flash, CH7525 can support DP input detection and determine to enter into Power saving mode automatically.

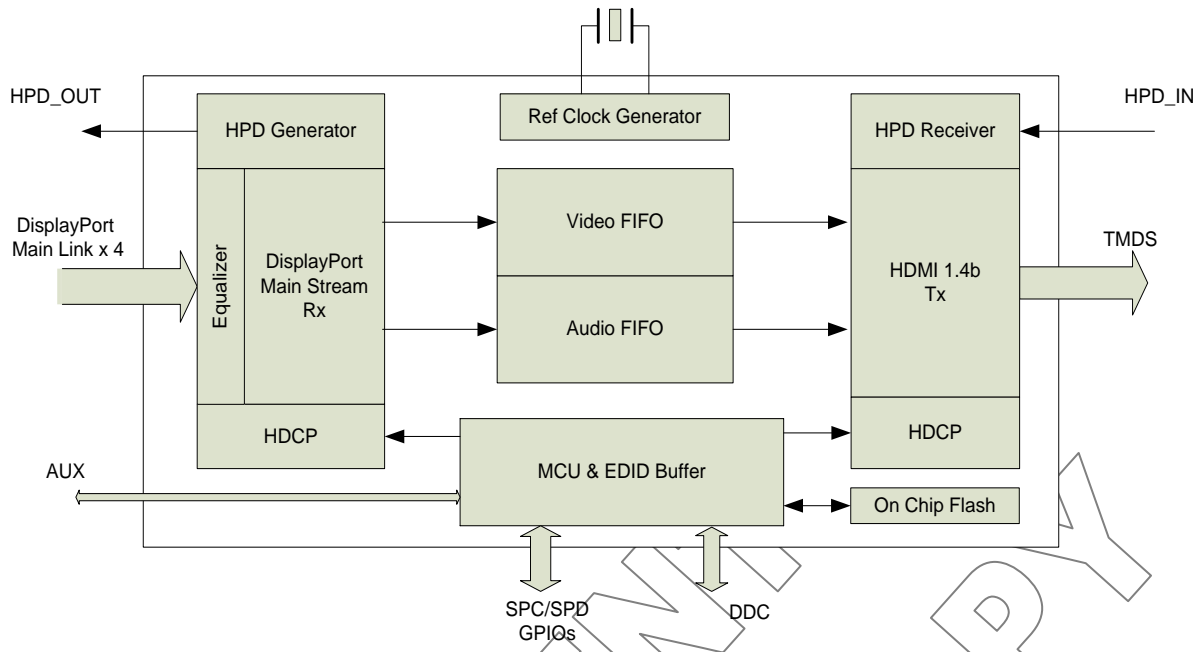

Figure 1: CH7525 Functional Block Diagram

CONFIDENTIAL
DO NOT COPY

1.0 PIN-OUT

1.1 Package Diagram

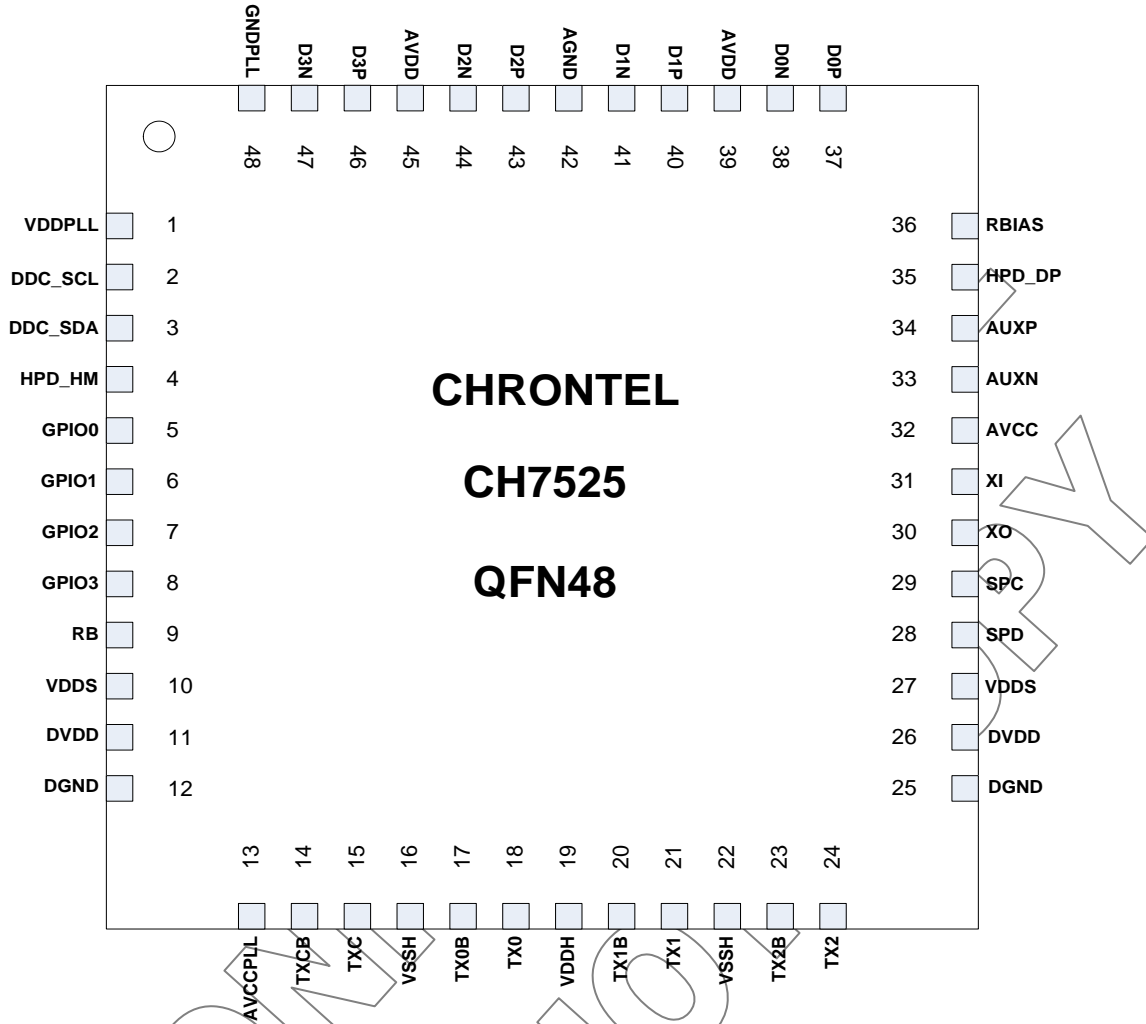

Figure 2: CH7525 48-Pin QFN Pin Out

1.2 Pin Description

Table 1: Pin Name Descriptions

| Pin # | Type | Symbol | Description |
|---------------------------|--------|------------|--|
| 2 | Out | DDC_SCL | Serial Port Clock Output to HDMI Receiver The pin should be connected to clock signal of HDMI DDC. This pin requires a pull-up 1.8 kΩ resistor to the desired voltage level |
| 3 | In/Out | DDC_SDA | Serial Port Data to HDMI Receiver The pin should be connected to data signal of HDMI DDC. This pin requires a pull-up 1.8 kΩ resistor to the desired voltage level |
| 4 | In | HPD_HM | HDMI Transmitter Hot Plug Input |
| 5~8 | In/Out | GPIO[3:0] | General Purpose Input/Output |
| 9 | In | RB | Reset* Input (Internal pull-up) When this pin is low, the device is held in the power-on reset condition. When this pin is high, reset is controlled through the serial port register. |
| 14,15 | Out | TXCB, TXC | HDMI Tx Clock Outputs These pins provide the differential clock output for the DVI. |
| 17,18 | Out | TX0B, TX0 | HDMI Tx Data Channel 0 Outputs These pins provide the TMDS differential outputs for data channel 0 |
| 20,21 | Out | TX1B, TX1 | HDMI Tx Data Channel 1 Outputs These pins provide the TMDS differential outputs for data channel 1 |
| 23,24 | Out | TX2B, TX2 | HDMI Tx Data Channel 2 Outputs These pins provide the TMDS differential outputs for data channel 2 |
| 28 | In/out | SPD | Serial Port Data Input / Output This pin functions as the bi-directional data pin of the serial port. External pull-up 6.8 KΩ resistor is required |
| 29 | In | SPC | Serial Port Clock Input This pin functions as the clock pin of the serial port. External pull-up 6.8 KΩ resistor is required |
| 30 | Out | XO | Crystal Output A parallel resonance crystal should be attached between this pin and XI / FIN. However, if an external CMOS clock is attached to XI/FIN, XO should be left open |
| 31 | In | XI | Crystal Input / External Reference Input A parallel resonance crystal should be attached between this pin and XO. However, an external 3.3V CMOS compatible clock can drive the XI Input |
| 33,34 | In/Out | AUXP, AUXN | AUX Channel Differential Input/Output These two pins are DisplayPort AUX Channel control, which supports a half-duplex, bi-directional AC-coupled differential signal. |
| 35 | Out | HPD_DP | DP Receiver Hot Plug Output |
| 36 | Input | RBIAS | Current Set Resistor Input This pin sets the basic current for internal circuit. A 10KΩ, 1% tolerance resistor should be connected between this pin and AVSS using short and wide traces |
| 37,38,40, 41,43,44, 46,47 | In | D[3:0]P/N | DP Main Link Differential Line Input These pins accept four AC-coupled differential pairs signals from the DisplayPort transmitter. |
| 1 | Power | VDDPLL | PLL Power Supply (1.2V) |
| 10,27 | Power | VDDS | Digital Serializer Power Supply (1.2V) |
| 11,26 | Power | DVDD | Digital Core/IO Power Supply (1.2V) |
| 12,25 | Power | DGND | Digital Ground |

| | | | |
|-----------------------|-------|---------|------------------------------------|
| 13 | Power | AVCCPLL | PLL Power Supply (3.3V) |
| 16,22 | Power | VSSH | HDMI Tx Ground |
| 19 | Power | VDDH | HDMI Tx Power Supply (3.3V) |
| 32 | Power | AVCC | Analog Power Supply (3.3V) |
| 39,45 | Power | AVDD | Analog Power Supply (1.2V) |
| 42, Thermal Pad | Power | AGND | Analog Ground |
| 48 | Power | GNDPLL | PLL Ground |

CONFIDENTIAL
DO NOT COPY

2.0 PACKAGE DIMENSION

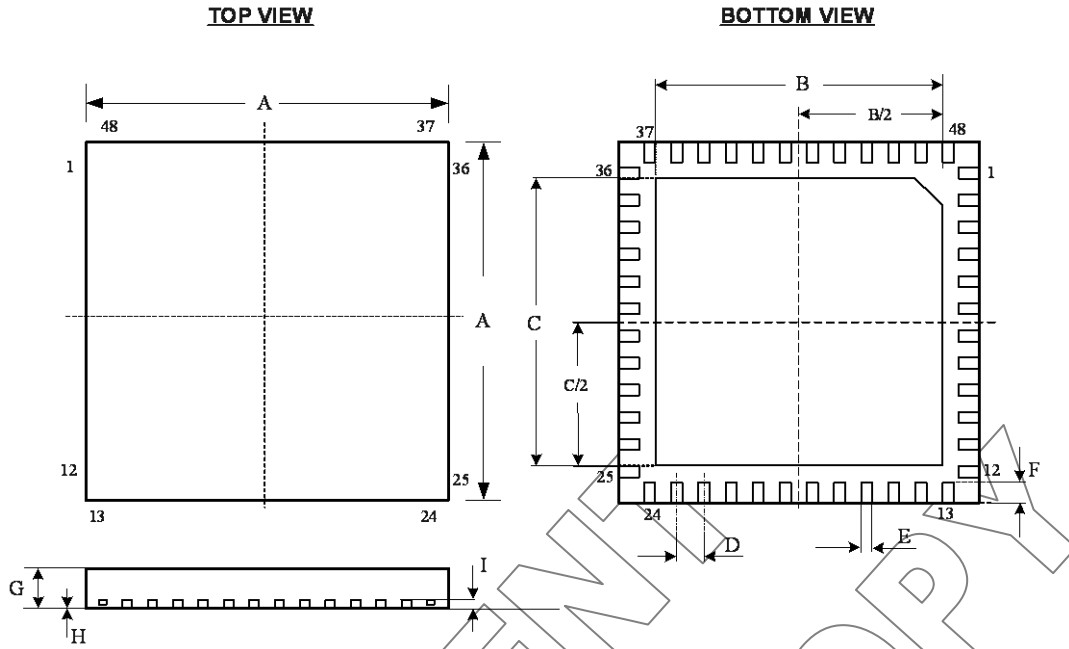

Figure 3: 48 Pin QFN Package

Table of Dimensions

| No. of Leads | | SYMBOL | | | | | | | | |
|---------------|-----|--------|------|------|-----|------|------|------|------|-------|
| 48 (6 X 6 mm) | | A | B | C | D | E | F | G | H | I |
| Milli-meters | MIN | 5.90 | 4.35 | 4.35 | 0.4 | 0.13 | 0.30 | 0.70 | 0 | 0.20 |
| | NOM | 6.00 | 4.50 | 4.50 | | 0.19 | 0.40 | 0.75 | - | - |
| | MAX | 6.10 | 4.65 | 4.65 | | 0.25 | 0.50 | 0.80 | 0.05 | 0.203 |

Notes:

Conforms to JEDEC standard JESD-30 MO-220.

Disclaimer

This document provides technical information for the user. Chrontel reserves the right to make changes at any time without notice to improve and supply the best possible product and is not responsible and does not assume any liability for misapplication or use outside the limits specified in this document. CHRONTEL warrants each part to be free from defects in material and workmanship for a period of one (1) year from date of shipment. Chrontel assumes no liability for errors contained within this document. The customer should make sure that they have the most recent data sheet version. Customers should take appropriate action to ensure their use of the products does not infringe upon any patents. Chrontel, Inc. respects valid patent rights of third parties and does not infringe upon or assist others to infringe upon such rights.

Chrontel PRODUCTS ARE NOT AUTHORIZED FOR AND SHOULD NOT BE USED WITHIN LIFE SUPPORT SYSTEMS OR NUCLEAR FACILITY APPLICATIONS WITHOUT THE SPECIFIC WRITTEN CONSENT OF Chrontel. Life support systems are those intended to support or sustain life and whose failure to perform when used as directed can reasonably expect to result in personal injury or death.

| ORDERING INFORMATION | | | |
|-----------------------------|---------------------|------------------------------------|-------------------------------|
| Part Number | Package Type | Operating Temperature Range | Minimum Order Quantity |
| CH7525A-BF | 48 QFN, Lead-free | Commercial : 0 to 70°C | 490/Tray |
| CH7525A-BFI | 48 QFN, Lead-free | Commercial : -40 to 85°C | 490/Tray |

Chrontel

www.chrontel.com

E-mail: sales@chrontel.com